



---

# SCENESETTER CED

---

*user manual*

©Abstract Design to Light 1996 Tel:0116 278 8078

---

Scenesetter CED Instruction Manual - Issue 1.0: Sep 96 (software v2.0)  
Written for Abstract Design to Light by Tim Mitchell, Sabre Technology Ltd: 01482 831031

## Dipswitch setting codes

To work out how you need to set the dipswitches to get a certain channel, follow this procedure.

Dip switch 1 adds 1 to the channel number when turned 'on'.

Dip switch 2 adds 2

Dip switch 3 adds 4

Dip switch 4 adds 8

Dip switch 5 adds 16

Dip switch 6 adds 32

Dip switch 7 adds 64

Dip switch 8 adds 128

Dip switch 9 adds 256

So to set a channel of 9, you need to turn on switches 4 and 1; for a channel of 50, turn on 6,5 and 2.

You can get round having to set the dip switches by using the auto channel set function (see page 8).

If you set the dipswitches to DMX channels 509 (1 on, 2 off, 3-9 on), 510 (1 off, 2-9 on) or 511 (1-9 on) then the unit will set itself to channel 1 as these are not valid settings for a 4-channel unit. These settings have a special meaning if the unit is in standalone mode (see page 6).

## Introduction

This booklet describes how you connect up the Abstract Scenesetter CED and how you make it work. It is divided up into sections:

- The connections you can make to the unit
- How you operate the unit
- Possible problems you might encounter
- Reference for the DMX implementation of the unit.

The Abstract Scenesetter CED is a complex intelligent lighting effect with the following features:

- Eleven dichroic colours + white
- Twelve gobos
- Smoothly microstepped mirror with automatic speed sensing
- Microstepped colour wheel with smooth colour crossfading
- High speed gobo changing with variable speed strobe
- Controlled by standard DMX512, any channel 1-508
- Automatic switch to 'stand alone' mode when DMX disconnected
- Sophisticated 'stand alone' 2-channel light show
- Unique automatic DMX channel selection system
- DMX channel can be changed while unit is running
- DMX switch-through relay in case of unit failure
- DMX/Audio beat indication LED

### Back panel features

1. **DMX output socket** (pin 3 cold, pin 2 hot, pin 1 grounded). Other DMX devices can be linked in to the system through this socket. In stand alone mode the unit outputs its own DMX through this socket.
2. **DMX input plug** (pin 3 cold, pin 2 hot, pin 1 screen). A dedicated controller or DMX lighting desk can be connected to this plug. The unit buffers the DMX signal, so you must make sure you get the connectors the right way round.
3. **Power on LED** (red). This LED is lit whenever the unit is powered up.
4. **DMX present / Audio beat LED** (green). This LED is on constantly when DMX is being received (it may flicker in time with the DMX frames), and goes out when DMX is not received. If the LED is not lit, then the unit is in stand alone mode and the LED will flash when an audio beat is detected.

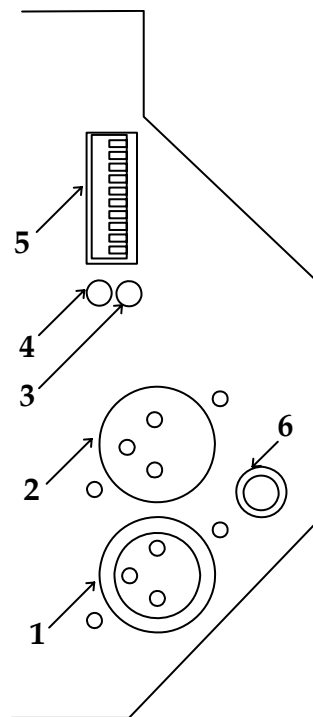

Gobo (Channel 2)

DMX	Result
0	Blackout
24	Open
38	Laser
58	Star
72	Slice
88	Tunnel
102	Heart
120	Eurostars
128	Sunburst
158	Triangle
174	Slash
190	Bubbles
206	Segment
222	Bubbles
226	Slow strobe
230	Strobe 2
234	Strobe 3
238	Strobe 4
242	Strobe 5
246	Strobe 6
250	Strobe 7
254	Fast strobe

Note: the gobo controller 'snaps' to the next gobo

#### Special functions

If all control channels are zero for longer than 10 seconds, the unit will go into 'standby' mode. Normal operation is restored by moving any control channel to a non-zero position.

## DMX implementation

Colour (Channel 1)

DMX	Result
10	White
26	Red
43	Blue
59	Green
75	Yellow
91	Cyan
108	Orange
124	Magenta
140	Neon Green
156	UV blue
173	Pink
189	Aqua
205	Aqua
221	Pink
238	UV blue
254	Neon Green

NB: Intermediate values will give mixed colours

- Dip switches.** Dip switches 1-9 set the DMX channel that the unit will respond to (in binary code). Channel 1 is the first valid DMX channel. If all switches 1-9 are off, the unit will automatically set its own DMX channel. Switch 10 sets the stand alone 'group' of the unit, either 1 (off) or 2 (on).
- Microphone.** The unit can sense the beat of the music through this built-in microphone.

*Note: when power is not connected to the unit, the DMX input and output connectors are bridged through by a relay to maintain the DMX circuit.*

## Connecting the unit up

---

You can use the unit in two ways:

- Stand alone mode, where the unit listens to the music and generates its own complex lightshow
- DMX control mode, where you connect a controller or lighting desk to the unit and control its movements yourself.

### Stand alone mode

The CE range of Abstract products have a sophisticated built-in lightshow, which is compatible across the whole range of products - you can connect any mix of units together and a fascinating synchronised lightshow will be produced.

#### *One unit only*

If you have only one unit, all you need to do is connect the power. The unit will listen to the music with its built-in microphone and produce a complex and dynamic sound animated light show using its built-in memory.

#### *Several units*

If you have more than one unit, you could run them all in stand-alone mode. However, there is a much better way of using the units which will result in a much more spectacular light show. You can connect the units together using DMX cables; the first unit will then control the other units to give an automatic synchronised light show.

Connect the DMX out (the socket) on the first unit to the DMX in (plug) on the second unit using a balanced XLR lead. Repeat this connection for all units.

## Specifications

---

Colours: White + 11 dichroic

Gobos: Open +11

Lamp: A1/232 150W 15V (3CE unit)  
GE Arcstream 4000K 150W (3CED unit)

DMX: Receive on 1-508  
Transmit on 1-8 (stand alone mode)  
DMX active regeneration when not stand alone

Audio: Electret mic with AGC

Power consumption: 300W approx.

Electronics fuse: T3.15A

It is recommended that the lamp is replaced before the end of its working life as the light output begins to deteriorate.

If your DMX connections are fairly short, you will get away with using ordinary microphone cables. For longer runs this may cause data transmission problems (which will show up as random or incorrect movements); you should use proper balanced data transmission cable.

***Unit does not move properly when controller on fast chase***

If the controller is changing very rapidly, the unit may not be able to keep up. It will 'average' the changes, which may result in it doing things you do not expect. Either slow the chase down, or set positions which are closer together.

***Unit moves very slowly in standalone mode***

Check the dipswitches are not set to the special option settings. You can set a special mode which makes the unit move slowly all the time.

***Unit does not respond to sound***

Check that the unit is not receiving DMX (the green LED should be off). Also check that the unit is not set to 'display' mode (see page 6) as it does not respond to sound in this mode. Otherwise, tapping the microphone should cause the LED to flash (quiet or high pitched sounds will not activate the unit).

***Unit blacks out in standalone mode***

Some of the unit's built in patterns include special effects such as blackout sweeps. If you connect two units you will find that only one is ever blacked out at once, and the blackout 'swaps' between the units.

If you cannot resolve the problem, it may be that the unit has a fault. You should contact your Abstract dealer.

***2-channel stand alone operation***

To add further interest to the light show you can set each unit to either follow the first unit or to do something in contrast to the first unit. For example, if you have four units, two on the right and two on the left, you might want to set the outside two units to do one thing, and the middle two to do a variation on the same theme.

You do this by setting dip switch 10 'off' to make them work the same and 'on' to make them work differently. Even if you only have two units you will probably find that you get a better light show if you set dip switch 10 'on' on the second unit.

*Note: Dip switch 10 has no effect on the first unit in the DMX line (the one generating the light show).*

***Special options in stand alone mode***

In stand alone mode, you can also set three options which affect the way the unit produces its light show, by setting the other 9 dip switches (1-9):

- All dip switches on: Display mode - unit ignores audio and scans slowly through various patterns
- 1 off, 2-9 on: Slow mode - unit responds to audio but always moves slowly and gently. No strobing is used.
- 1 on, 2 off, 3-9 on: Strobe disable mode - unit behaves as for normal stand-alone mode but will not use strobing.

These options only need to be set on the first unit in the DMX line if several units are connected together. You can set the switches before or after the unit is turned on.

If you connect a DMX source while these special options are set, the unit will have a start channel of 1.

## DMX controlled mode

DMX is a control system which allows 512 lighting control channels to be sent down one piece of wire. The DMX signal 'flows' in one direction starting at the controller you are using, through each unit, to the last unit in the line.

*Note: The DMX signal is 'buffered' in each unit and can only flow one way through the unit: into the plug, and out of the socket. If you connect the DMX cables to the wrong connectors, the DMX signal will be blocked.*

### Setting the 'base channel'

When using DMX, all the units receive all the channels. You need to tell each unit which channel to respond to (its 'base channel'). There are two ways to do this:

- Set the dip switches to the binary equivalent of the channel you want the unit to respond to (see page 17 for help!).
- Use the Auto Channel Set feature, which will configure the system automatically.

The unit actually responds to two DMX channels, one each for colour and gobo. So if you set the dip switches to DMX channel 1 (switch 1 on, all others off), then channel 1 will control colour and channel 2 gobo. The next free channel is therefore channel 3. Page 17 of this booklet describes in more detail how to work out the channel numbers.

*Note: if you want two units to behave exactly the same, you can set the dip switches for both units to the same channel.*

You can change the dipswitches while the units are running, and the new settings will take effect immediately. You don't need to reset the unit.

## If you have problems

The next section lists a few common problems you may encounter, with solutions.

### *No light from the unit.*

Check the 'Power on' (red) LED is lit and the fan is running. If not, there is no mains supply. Check the fuse in the back panel.

Check if the lamp is alight. You should be able to see some light escaping through the fan. If power is present but the lamp is not alight it may need replacing.

*Note: if the unit is in standby mode because all its control channels are at 'zero' position, it may have turned the lamp off (3CE only) . Set some controls to non-zero positions.*

If the lamp is alight, check that the Gobo wheel is not in blackout position. If you are using a controller, change the gobo. If in stand alone mode, tap the microphone a few times.

### *Unit not responding to DMX.*

If the DMX LED (green) on the rear of the unit is lit, the unit is definitely receiving DMX but is probably not responding to the channel you think it is. Check the dipswitch settings. If using auto set, check the dipswitch settings on the first unit in the line.

If the DMX LED is not lit, check that your DMX cables are connected properly and are wired correctly (pin 2 is 'hot'; on some other DMX devices pin 3 may be 'hot'). Also check you have connected the cables to the right connectors; it does matter which way round they are.

If you have a bad connection, you may see the DMX LED flash on and off as you wiggle it (but remember it may also be the unit sensing audio!)

## Compatibility with other units

This unit is compatible with all units in the Abstract CE range. You will find that some colours and gobos are repeated to allow matching with the other units in the range.

In stand-alone mode, you should use the most complex unit as the controller as more features may have been provided on it.

In DMX controlled mode you will probably want to use the different types of unit on different DMX channels to this unit.

### *Auto Channel Setting*

The 'Auto Channel Set' feature of the units takes away all the fuss and confusion of fiddling with dip switches and working out binary numbers. Simply switch all the dip switches to 'off', connect up the DMX cables, turn on the power and the units will automatically number themselves; the first unit will operate on channels 1-4, the second on 5-8, and so on.

Make sure that the DMX cabling is all connected and that the first unit in the DMX line is turned on last. If it doesn't work, turn the first unit in the DMX line off and on again, or change its dipswitches.

If you don't want the numbering to start at channel 1, set the dipswitches on the first unit to the channel you want it to start at. All the other units will then set themselves to the correct channels following that one.

*Note: If any unit cannot determine what channel it should set itself to, it will choose channel 1. You can force the 'Auto Channel Set' to be repeated by changing the switches on the first unit in the DMX line or by turning it off and on again.*

Once running, if you change the dip switches on the first unit, the 'Auto Set' is repeated. All units further down the DMX line which are in 'Auto Set' mode will be reconfigured. If any unit in the DMX line is not in 'Auto Set' mode, the numbering will restart at that unit.

If you change the dip switches on a unit which was in auto set mode (switches were all 'off'), the unit will immediately take on the new channel you set. If you then go back to the auto set mode, the unit will remain at the channel it was previously set to until it receives an 'Auto Set' command from further up the DMX line.



## Operating the unit

---

When you power up the unit, it will go through an initialisation routine where it moves all the motors to their zero positions. The unit may make some quite alarming noises but this is normal. The initialisation routine takes about 15 seconds, after which the unit will begin to respond to DMX input, or to sound if no DMX is connected.

### Unit in stand alone mode

If the unit is in stand alone mode, you have no control over it at all. You can take control of the unit at any time by connecting a DMX source to it.

You can set several special options which affect how the unit behaves in stand alone mode; see page 6.

*Note: If you connect other manufacturers' products to the DMX output while the unit is in stand alone mode, you may find that they do not respond correctly (or at all).*

### Unit in DMX controlled mode

The unit responds to two DMX channels, starting at the one set on the dipswitches (or the one following the last channel of the previous unit if auto-channel set has been used).

You can use either a dedicated controller or any other DMX lighting controller to drive the unit; also you can connect another unit in stand-alone mode which will generate its own lightshow.

On the first channels (colour), the unit senses the speed of the controller movement and matches its movement speed as closely as possible. If you move the control very slowly, the unit will move very slowly. If you move the control very quickly, the unit will move as fast as it can.

There is a limit to how fast the unit can move; if you move the control faster than that, the unit will lag behind slightly. If you suddenly start moving the control in the opposite direction, the unit will slow down before reversing direction to keep in control of the movement.

*Note: if the controller is changing faster than the unit can move, the movement may be a bit unpredictable. Slow down the control movements until the unit can match the speed.*

On the 2nd channel (gobo), the unit 'snaps' to the nearest gobo. If you move the control slowly, nothing will happen until the unit senses you are near the next gobo position, when it will move on to the next gobo. If you move the control to the top end of its range (about 80%) you will enter the 'strobe zone'. The unit will strobe slowly (about one flash per second) at 80%, up to full speed strobe (about 10 flashes per second) at 100%.

*Note: the 'zero' position on the gobo wheel is a blackout. The unit will not emit any light until you move the gobo control away from the 'zero' position.*

If all control channels of the unit are left at 'zero' position for more than about 10 seconds, the unit will go into 'standby' mode. The unit will go back to normal as soon as any control channel is moved off the 'zero' position.